

3/17/2011



NEXT
GENERATION

5G THE NANOCORE

Research Paper On 5G | Imthiyaz Ali

Précis:

Telecommunications is the growth Engine of the modern science & technology. Mobile network infrastructures are being deployed at a rapid pace around the globe, with the capabilities and bandwidth to finally deliver human needs as per the requirement.

This white paper will show a personal view on 5G networks, especiacially for Operators & services providers. The document has been separated in to 4 parts. Which deals with Evolution of Wireless technology, Latest 4G trends, Need for 5G? 5G-The NanoCore depiction.

It will also illustrate the need for incorporation of Nanotechnology, Cloud computing, as well as All IP network to form a global NanoCore as a 5G network. Mentioned Design, Technologies, Dates, values, in this paper are just predication.

“One cannot Manage change
One can only be Ahead of it”

About the Author:

Imthiyaz Ali is a senior software engineer of Wipro Technologies. He received his B.E degree in Electronics and communication from Anna University. His prior technical experience also includes Radio Network Optimization of Live network. He has authored papers on NanoRobot, Nanotechnology, and Wireless communications.

Synopsis:

- *Introduction*
 - *Moore’s Law.*
 - *Moore’s Law is dead.*
- *Evolution of Wireless technologies*
 - *Latest LTE Trends (SAE)*
- *Need for 5G?*
- *Flat IP Network*
- *5G-The NanoCore*
 - *Application*
 - *5G Architecture*
 - *Incorporated Technologies*
- *Nanotechnology*
 - *NanoEquipment(NE)*
 - *NanoCore Network*
- *Cloud Computing*
- *All IP Network*
- *NanoCore-As Managed Services*
- *Future Enhancement(Artificial intelligent)*
- *Risk & Challenges*
- *Conclusion*
- *References*
- *Case Study*

Introduction:

We are living in a world of science. Science makes our life more beautiful than the most. Modern world is shrinking due to the development of science and its technology. Technology has detached the word "impossible" from real world. Over the years, wireless telecommunications market has long been recognized as one of the most dynamic and fastest growing segments of the global telecommunications industry. The global telecom market is expected to grow at CAGR close to 4.2% to reach EUR 3.1 trillion by the end of 2011

We are existing in an innovative world of science where technologies are matured enough to fulfill human desires. But requirements of human being augment day by day. Individual is ready to set up all sort of possible technologies to fulfill his necessities. Outcome is what we have today as Nanotechnology, All IP, Cloud computing, LTE. These are some of the technologies used by human to balance his needs. But "*Nothing is sufficient for the person who finds sufficiency too little*". However further modernization will be on convergence of this existing technology into a single platform. This paper too deals the same, here we have tried to converge some of the existing technologies (i.e) Nanotechnology,

Cloud Computing, All IP, and LTE into a single core network "The Nanocore" Which could be a possible 5G Wireless network.

Moore's Law: Future wireless mobile communications will be shifted from today's traditional transmission-specific radio technology to an interface-based technology in order to be more compatible with computer system architecture. The future mobile device will therefore be first and foremost a computer till today wireless Telecommunication is bounded by Moore's law. Moore's law describes a long-term trend in the history of computing hardware. The number of transistors that can be placed inexpensively on an integrated circuit has doubled approximately every two years.[1] The trend has continued for more than half a century and is not expected to stop until 2015 or later. This law sounds well up to LTE Advance which is considered as a latest wireless trend. But next generation wireless communication will certainly break Moore's law. Hence Moore's law is no more its dead.

Moore's Law is dead:

"**Moore's Law is dead**", according to Gordon Moore, its inventor.

Moore's Law is commonly reported as a doubling of transistor density every 18 months. But this is not something the

co-founder of Intel, Gordon Moore, has ever said. It is a nice blending of his two predictions; in 1965, he predicted an annual doubling of transistor counts in the most cost effective chip and revised it in 1975 to every 24 months. With a little hand waving, most reports attribute 18 months to Moore's Law, but there is quite a bit of variability. The popular perception of Moore's Law is that computer chips are compounding in their complexity at near constant per unit cost. This is one of the many abstractions of Moore's Law, and it relates to the compounding of transistor density in two dimensions. Others relate to speed (the signals have less distance to travel) and computational power (speed x density).

The usable limit for semiconductor process technology will be reached when chip process geometries shrink to be smaller than 20 nanometers (nm), to 18nm nodes. At those nodes (levels), the industry will start getting to the point where semiconductor manufacturing tools are too expensive to depreciate with volume production, i.e., their costs will be so high, that the value of their lifetime productivity can never justify it."

At this point nanotechnology comes in to picture. Nanotech is often defined as the manipulation and control of matter at the nanometer scale (critical dimensions of 1-100nm). The primary contender for the post-silicon computation paradigm is molecular electronics, a nano-scale alternative to the CMOS transistor. Eventually, molecular switches will revolutionize

computation by scaling into the third dimension - overcoming the planar deposition limitations of CMOS. Nantero employs carbon nanotubes suspended above metal electrodes on silicon to create high-density nonvolatile memory chips. Carbon nanotubes are small (~10 atoms wide), 30x stronger than steel at 1/6 the weight, and perform the functions of wires, capacitors and transistors with better speed, power, density and cost.

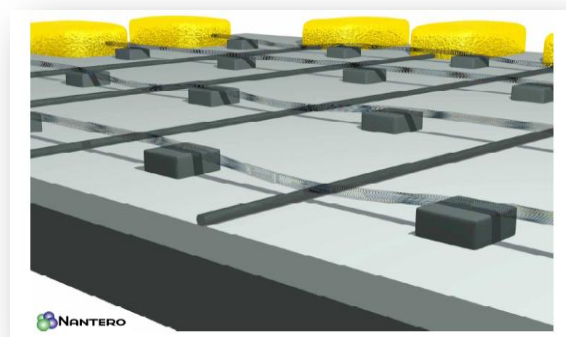

Evolution of Wireless Technologies:

In 1895, Guglielmo Marconi opened the way for modern wireless communications by transmitting the three-dot Morse code for the letter 'S' over a distance of three kilometers using electromagnetic waves. From this beginning, wireless communications has developed into a key element of modern society. From satellite transmission, radio and television broadcasting to the now ubiquitous mobile telephone, wireless communications has revolutionized the way societies function. The evolution of wireless begins here.

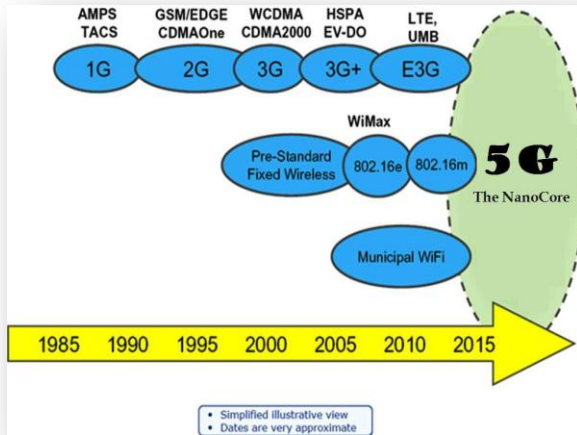

1G: The 1st generation was pioneered in early 1980's. First generation cellular mobile telephones developed around the world using different, incompatible analogue technologies. It support speed up to 2.4kbps. Major contributors were AMPS, NMT, and TACS. In terms of overall connection quality, 1G compares unfavorably to its successors. It has low capacity, unreliable handoff, poor voice links, and no security at all since voice calls were played back in radio towers, making these calls susceptible to unwanted eavesdropping by third parties.

2G: The 2nd generation was accomplished in later 1990's. 2G mobile telephones used digital technology. Group Special Mobile (GSM) was first developed in the 1980s and was the first 2G system. Mainly used for Voice communication and supports speed up to 64kbps. Another advantage of 2G over 1G is that the battery life of a 2G handset lasts longer, again due to the

lower-powered radio signals. Since it transmitted data through digital signals, 2G also offered additional services such as SMS and e-mail. Major prominent technologies were GSM, CDMA, and IS95.

2.5G: In term "2.5G" usually describes a 2G cellular system combined with General Packet Radio Services (GPRS), or other services not generally found in 2G or 1G networks. A 2.5G system may make use of 2G system infrastructure, but it implements a packet-switched network domain in addition to a circuit-switched domain..It can support data rate up to 144kbps.GPRS, EDGE, & CDMA 2000 were the focal 2.5G technologies. This does not necessarily give 2.5G an advantage over 2G in terms of network speed, because bundling of timeslots is also used for circuit-switched data services (HSCSD).

3G: An attempt to establish an international standard for 3G mobile is being moderated through the ITU, under the auspices of its IMT-2000 program. It was inveterate in late 2000.It provides transmission speed up to 2Mbps. Third generation (3G) services combine high speed mobile access with Internet Protocol (IP)-based services. Apart from transmission speed innovative enhancement was made in Quality of services. Add on services such as global roaming, better voice quality, always on made 3G as a significant generation. In addition to

being more expensive, 3G handsets also require more power than most 2G models. The major disadvantage for 3G network plans centers around pricing. Generally, 3G network price points are much higher than 2G networks with comparable features.

4G: Mobile operators face a decision: Their 3G networks will soon be overwhelmed by the amount of data traffic they're handling. And demand is growing faster and faster as customers become accustomed to "anywhere, anytime" access to the Internet. How can operators expand capacity while continuing to lower operating costs to maintain their margins and keep customers happy?

We believe that the future of mobile data services lies with Long-Term Evolution technology, or LTE. Offering vastly improved network performance at just a fraction of the cost of 3G technology, LTE has the capabilities to greatly expand network capacity and offer a large number of customers the ability to access a wide range of high-speed services such as video-on-demand, peer-to-peer file sharing, and complex Web services. At the same time, additional spectrum is becoming available that will enable operators to manage their networks more flexibly, offering greater coverage and better performance for less money.

4G usually refers to the successor of the 3G and 2G standards. In fact, the 3GPP is currently standardizing LTE Advanced as future 4G standard. A 4G system may upgrade existing

communication networks and is expected to provide a comprehensive and secure IP based solution where facilities such as voice, data and streamed multimedia will be provided to users on an "Anytime, Anywhere" basis and at much higher data rates compared to previous generations. One common characteristic of the new services to be provided by 4G, is their demanding requirements in terms of QoS. Applications such as wireless broadband access, Multimedia Messaging Service (MMS), video chat, mobile TV, HDTV content and Digital Video Broadcasting (DVB) are being developed to use a 4G network.

4G Architecture:

In parallel with the LTE radio access, packet Core networks are also evolving to the flat SAE architecture. This new architecture is designed to optimize network performance, improve cost efficiency and facilitate the uptake of mass market IP-based services.

The Evolved Packet Switched System (EPS) provides IP connectivity between a UE and an external packet data network using the Evolved Universal Terrestrial Radio Access Network (E-UTRAN). Consists of an Evolved Packet Core (EPC) and Evolved UTRAN (E-UTRAN). E-UTRAN consists of eNBs, providing the E-UTRA user plane and control plane protocol terminations towards the UE.

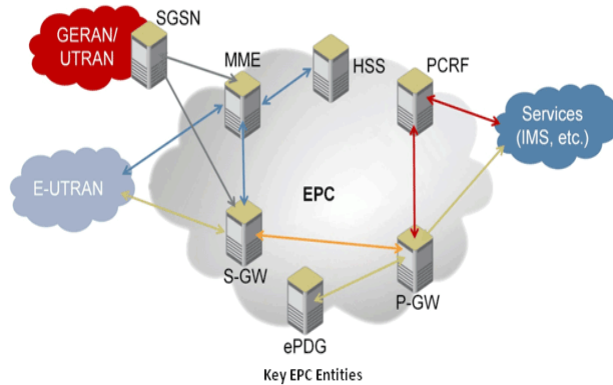

The goals for LTE include improving spectral efficiency, lowering costs, improving services, making use of new spectrum and reformed spectrum opportunities, and better integration with other open standards.

LTE Advanced Requirements:

The requirement specification TR 36.913 has already been approved in TSG-RAN#40. Detailed Technical proposals will be investigated within the working groups.

Current agreements on the requirements for LTE Advanced:

- Peak data rate DL: 1 Gbps, UL: 500 Mbps
- Transmission bandwidth: Wider than approximately 70 MHz in DL and 40 MHz in UL
- Latency: C-plane from Idle (with IP address allocated) to Connected in <50 ms and U plane latency shorter than 5 ms one way in RAN taking into account 30% retransmissions (FFS)
- Cell edge user throughput 2 times higher than that in LTE
- Average user throughput 3 times higher than that in LTE
- Capacity (spectrum efficiency) 3 times higher than that in LTE

- Peak spectrum efficiency DL: 30 bps/Hz, UL: 15 bps/Hz
- Spectrum flexibility: Support of scalable bandwidth and spectrum aggregation
- Mobility: Same as that in LTE
- Coverage should be optimized or deployment in local areas/micro cell environments with ISD up to 1 km
- Backward compatibility and interworking with LTE with 3GPP legacy systems

LTE is not a revolutionary technology, nor is it meant to be. The goal of the technology is to be able to meet the future demand of wireless broadband access, and thus satisfy customer expectations of improved data transmission performance, as well as voice transmission, without having to pay more money. Ultimately, every operator has a choice: Move now to begin the transition to LTE and capture the early cost advantage, or wait until demand rises to the point where LTE investments become necessary.

Need for 5G?

Mobile broadband is becoming a reality, as the internet generation grows accustomed to having broadband access wherever they go and not just at home or in the office. Of the estimated 3.4 billion people who will have broadband by 2014, about 80 percent will be mobile broadband subscribers – and the majority will be served by High Speed Packet Access (HSPA) and Long Term Evolution (LTE) networks. There is strong evidence

supporting predictions of increased mobile broadband usage.

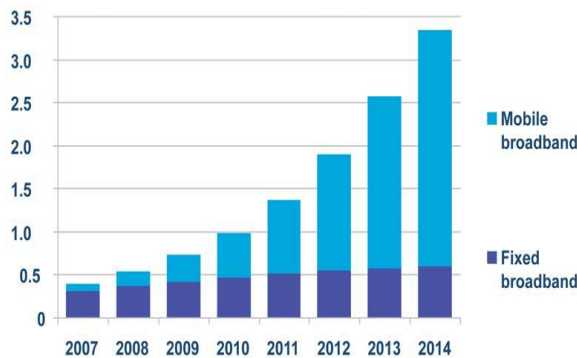

But you might have a uncertainty at this movement (i.e) all the above requirements are expected to be satisfied by LTE advance itself. Then why there is a need for 5G? Yes of course LTE might support peak data rate of DL: 1Gbps, UL: 500Mbps within a scalable bandwidth where the user can gratify his requirement.Inturn LTE advance provides beyond the demand. The actual dilemma starts here...

As per the present status all over the world WCDMA is commercially launched .Some nations has planned to launch LTE within next quarter. Operator is looking ahead for wide-scale deployment of LTE in 2012. Operators will also find that the timing is right to make the switch because much of the first generation of 3G equipment will need to be upgraded soon. LTE networking equipment and handsets, already under development, will become available in 2010, and should be rolled out in large quantities in Europe by 2012.

NUMBER OF MOBILE DEVICES SHIPPED WORLDWIDE ANNUALLY
SHARE OF LTE DEVICES, NUMBER OF LTE DEVICES, 2009-2020

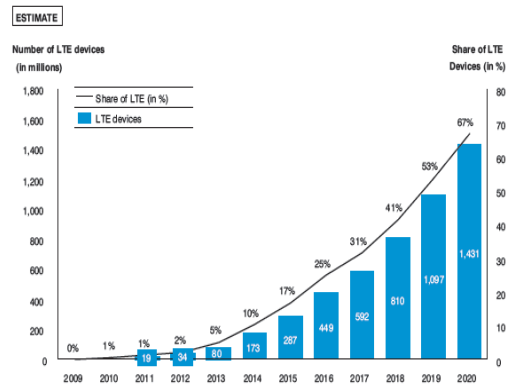

This clearly shows that within 2020 LTE will become the latest trend for wireless communication all over the world. But yet our question remains unanswered. Why there is a need for 5G?.Even though LTE provides wide range of growth for present wireless telecommunication. People are not in a circumstance to make use of those benefits in an effective manner.LTE might be rigorously used in Commercial/Industrial areas. But think of a common man who utmost utilize LTE for downloading a movie or make a video call. Fact is that there is no such ground-breaking application exists in real world to be utilized by a common man. You might doubt how this verdict is applicable for current innovative world, where we have enormous splendid real time applications. Concern is that our present wireless telecommunications is bottlenecked to use those applications in an effective manner. This paper mainly focuses on how a 5G network can provide more approach to a common man to utilize his available possessions in an immense way to make him to feel the real progress.

While considering a 5G network now it is very obvious that the access network is almost frozen and there will not be any further modification. Current OFDMA is appropriate for at least next half a century. Then what could be the amendment for 5G? Furthermore their won't be any alter in the wireless infrastructure as it happened from 1G to 4G instead there could be add-on application or up gradation done at the core network to satisfy customer needs. This will make the operators/Service providers to sense preminent to migrate for a 5G as soon as possible once 4G is commercially deployed.

While considering a smooth migration for 5G it is apparent that it should be valid for all sorts of radio access technologies. So that it could make better revenue for current global operators as well as interoperability will become more feasible. To make 5G practical for all sorts of radio access technologies there should be a common platform unique for all the technologies. One of those unique platforms is Flat IP network.

Flat IP network:

Certainly Flat IP network is the key concept to make 5G acceptable for all kind of technologies. To meet customer demand for real-time data applications delivered over mobile broadband networks, wireless operators are turning to flat IP network architectures. Flat IP architecture provides a way to identify devices using symbolic names, unlike the hierarchical architecture such as that used in

"normal" IP addresses. This is of more interest to mobile broadband network operators.

With the shift to flat IP architectures, mobile operators can:

- Reduce the number of network elements in the data path to lower operations costs and capital expenditure
- Partially decouple the cost of delivering service from the volume of data transmitted to align infrastructure capabilities with emerging application requirements
- Minimize system latency and enable applications with a lower tolerance for delay; upcoming latency enhancements on the radio link can also be fully realized
- Evolve radio access and packet core networks independently of each other to a greater extent than in the past, creating greater flexibility in network planning and deployment
- Develop a flexible core network that can serve as the basis for service innovation across both mobile and generic IP access networks
- Create a platform that will enable mobile broadband operators to be competitive, from a price/performance perspective, with wired networks

Flat network architecture removes that voice-centric hierarchy from the network. Instead of overlaying a packet data core on the voice network, separate and much-simplified data architecture can be

implemented that removes the multiple elements from the network chain.



But with the advantages of IP come some dangers - The Internet is open not just to well-meaning developers but also to all manner of criminals and vandals, and our always-on DSL connections bring us not only voice and video, but also viruses, along with phishing attacks and Trojan horses. That's why the developers of the next generation of mobile networks are trying to build security in from the start.

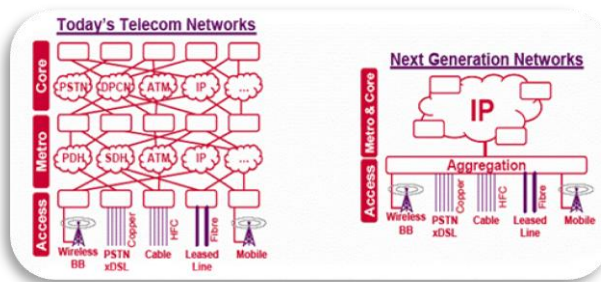

5G networks make use of this flat IP concept to make it easier for different RAN to upgrade in to a single NanoCore network. Our 5G network uses Nanotechnology as defensive tool for security concern that arises due to flat IP.

The fore coming sessions will deal how a NanoCore acts as a global server

for prevailing 5G networks. And what all the technologies incorporated in it to craft it as a global server.

5G -The NanoCore:

Applications:

How could be it..

- If you can able to feel yours kid stroke when she/he is in her mother's wombs.
- If you can able to charge your mobile using your own heart beat.
- If you can able to perceive your grandmother sugar level with your mobile.
- If you can able to know the exact time of your child birth that too In Nano seconds.
- If your mobile rings according to your mood.
- If you can Vote from your mobile.
- If you can get an alert from your mobile when some once opens your intelligent car.
- If you can able to view your residence in your mobile when someone enters.
- If you can able to locate your child when she/he is unfortunately missed.

- If you can able to pay all your bills in a single payment with your mobile.
- If you can able to sense Tsunami/earthquake before it occurs.
- If you can able to visualize lively all planets and Universe.
- If you can able to navigate a Train for which you are waiting.
- If you can get the share value lively.
- If you can lock your Laptop, car, Bike using your mobile when you forgot to do so.
- If you're mobile can share your work load.
- If you're mobile can identify the best server.
- If you're mobile can perform Radio resource management.
- If your mobile can intimate you before the call drops.
- If your mobile phone get cleaned by its own.
- If you can able to fold your mobile as per your desire.
- If you can able to expand your coverage using your mobile phones.
- If you can able identify your stolen mobile with nanoseconds.
- If you can able to access your office desktop by being at your bedroom.
- If you're mobile can able to suggest you possible medicine as per your healthiness.
- If you're mobile can able to calculate approximate Hike. 😊
- If you're mobile can estimate the quality of your new build house.
- If you're mobile can able to provide recent worth on products using its barcode.

Yes Of course, "Everything is possible for him who believes."Our 5G network will make everyone's belief come true.

5G Architecture - The NanoCore

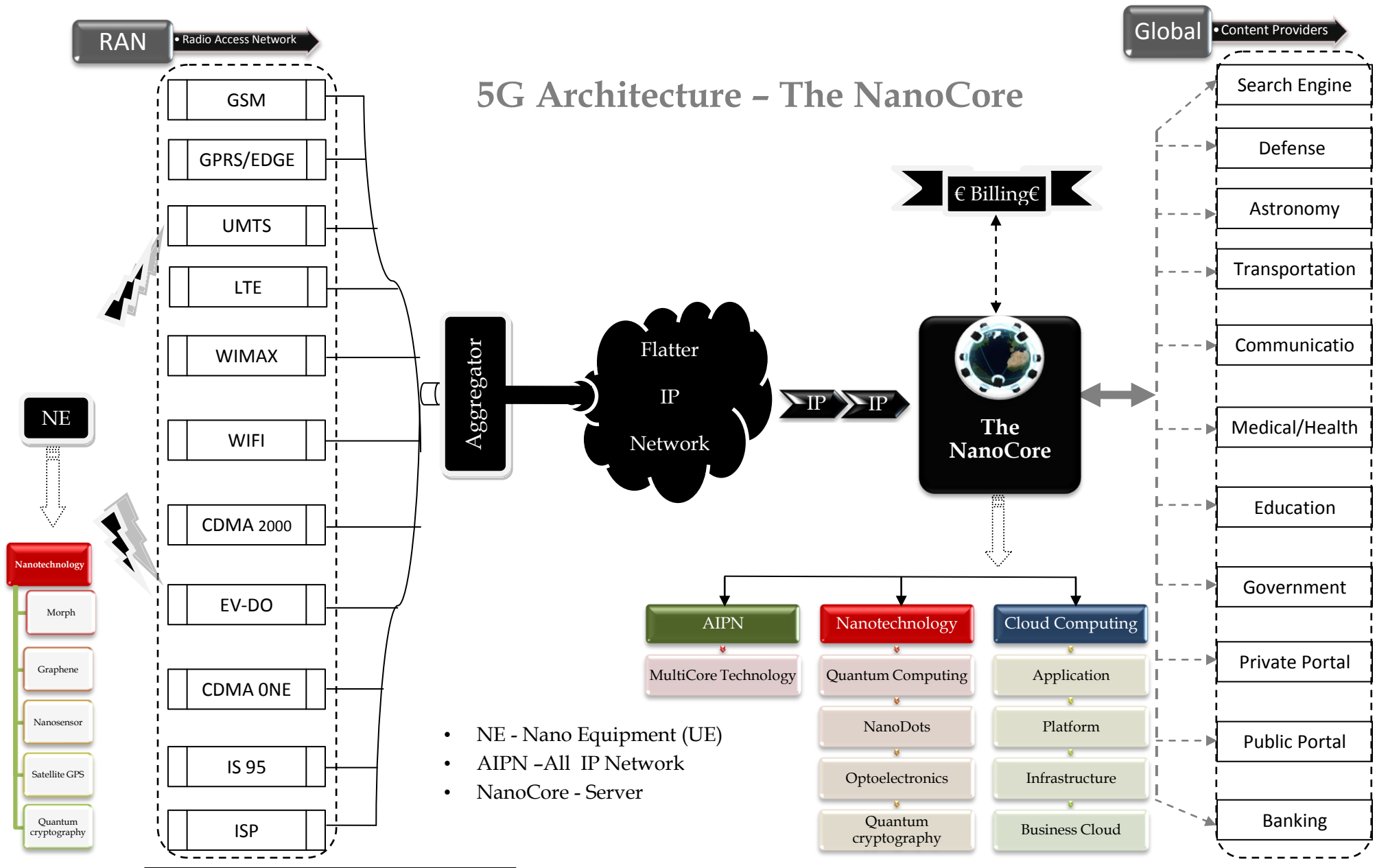

- NE - Nano Equipment (UE)
- AIPN -All IP Network
- NanoCore - Server

Incorporated Technologies:

Sophisticated technology has enabled an age of globalization. Technological convergence is the tendency for different technological systems to evolve towards performing similar tasks. What Nicholas Negroponte labeled the transformation of "atoms to bits," the digitization of all media content. When words, images and sounds are transformed into digital information, we expand the potential relationships between them and enable them to flow across platforms.

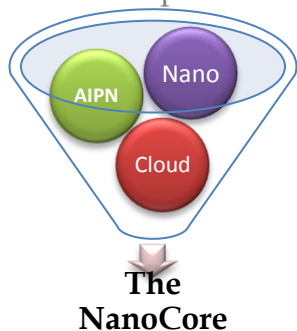

The 5G Nanocore is a convergence of below mention technologies. These technologies have their own impact on exiting wireless network which makes them in to 5G.

- Nanotechnology.
- Cloud Computing.
- All IP Platform.

Nanotechnology:

Nanotechnology is the application of nanoscience to control process on nanometer scale. i.e between 0.1 and 100nm. The field is also known as molecular nanotechnology(MNT).MNT

deals with control of the structure of matter based on atom-by-atom and molecule by molecule engineering. The term nanotechnology was introduced by Nori Taniguchi in 1974 at the Tokyo international conference on production engineering.

Nanotechnology is the next industrial revolution, and the telecommunications industry will be radically transformed by it in a few years. Nanotechnology has shown its impact on both mobile as well as the core network. Apart from this it has its own impact on sensor as well as security. This is considered as a most significant in telecommunication. We will be discussing the same in our further slides.

NanoEquipment (NE):

Mobile phone has become more than a communication device in modern world it has turned into an identity of an individual. In 5G Nanocore these mobile are referred as NanoEquipment as they are geared up with nanotechnology. One of the central visions of the wireless industry aims at ambient intelligence: computation and communication always available and ready to serve the user in an intelligent way.

This requires that the devices are mobile. Mobile devices together with the intelligence that will be embedded in human environments – home, office, public places – will create a new platform that enables ubiquitous sensing, computing, and communication

Specs of NanoEquipments:

- Self Cleaning - the phone cleans by itself
- Self powered - the phone derives its energy/power from the sun, water, or air.
- Sense the environment - the phone will tell you the weather, the amount of air pollution present, etc.
- Flexible - bend but not break
- Transparent - "see through" phones

Concept of Morph:

Nokia together with the University of Cambridge (UK), has developed this concept called Morph. Morph is from the Greek morphe meaning shape or form Morph is a concept that demonstrates how future mobile devices might be stretchable and flexible, allowing the user to transform their mobile device into radically different shapes. It demonstrates the ultimate functionality that nanotechnology might be capable of delivering: flexible materials, transparent electronics and self-cleaning surfaces.



Graphene's Transistor: The IBM scientists, sponsored by DARPA (the U.S. Defense Advanced Research Projects Agency), have built prototype transistors with the new material, called graphene. It is a form of graphite that consists of a single layer of carbon atoms arranged in a honeycomb pattern. Graphene's structure allows electrons to travel through it very quickly and gives it greater efficiency than existing transistor chip materials. IBM announced Thursday the researchers have achieved a frequency of 26GHz on prototype graphene transistors. Those frequencies are far above what cellular networks use today. There may be military and medical uses for frequencies above 1THz, such as seeing concealed weapons or doing medical imaging without using harmful x-rays.

But at conventional frequencies, graphene-based transceivers could make both cell phones and base stations more sensitive and better able to pick up weak signals. The key is signal-to-noise ratio, or being able to distinguish the radio signal from the other waves around it. At a given distance, a phone with a better signal-to-noise ratio can take better advantage of the signal available from the nearest cell tower. A more sensitive phone might even work in areas where today's phones can't.

GPS: Nanotechnology soon could enhance cell phones with carbon-nanotube vacuum tubes, microscopic microphones, liquid lenses, compasses linked with global positioning system satellites and even electronic noses.

Micro-Micro Phones: "We have two ears to help locate sounds in space. This helps us focus in on a single conversation in a noisy room. Having multiple microphones would allow us to be maximally sensitive to the sounds we want and minimally sensitive to the sounds we don't. This would help cut down the noise you hear over the phone.

Liquid lens: In the fixed lenses you have in cell phones, what happens is there is a lot of jitter, the image is a mess, but your eyes stay focused on what they're looking at -- do jitter reduction. So we want to make our optics as functional as what our own eyes have

Intelligent Batteries: Batteries consist of metal electrodes bathed in chemicals known as electrolytes. Plugging in a battery leads to electrolytes reacting, with electrons streaming through the electrodes. Over time, the electrolytes react on their own, which is why battery power drains even when they are not in use. The company is developing a battery crafted via semiconductor industry processes that contain millions of silicon nanotubes, atop each sits a droplet of electrolyte. If made to fall within the space between the tubes by applying a voltage change, the droplets react to create a current. This means the electrolytes activate only when in use.

Nanosensor: Impact of nanotechnology over mobile phones has made them to act as intelligent sensors. Nanosensors and nano-enabled sensors have applications in many industries, among them transportation, communications,

building and facilities, medicine, safety, and national security, including both homeland defense and military operations.

Few sensors today are based on pure nanoscience, and the development of nano-enabled sensors is in the early stages; yet we can already foresee some of the possible devices and applications.

- **Physical Sensors-** This approach may allow the mass of individual biomolecules to be measured.
- **Electrometers** - This device has demonstrated charge sensitivity below a single electron charge per unit bandwidth (~ 0.1 electrons/ Hz at 2.61 MHz), better than that of state-of-the-art semiconductor devices.
- **Chemical Sensors** - Various nanotube-based gas sensors have been described in the past few years.
- **Biosensors** - DNA detection with these nano-scale coded particles has been demonstrated.

At present further more researches are going on to realize nanotechnology for future mobile communication in different aspects. We can expect more enhancements in potential existence.

Nanotechnology over Core Network

The requirement of Nanocore evidently shows that it requires high speed and a reliable capacity to manipulate such a mammoth task as a

single entity and to maintain a poise in security aspects as perceptive data's will be transferred over air. Our most recent core (Wimax, LTE) can't be able to accomplish these requirements. But ingress of NanoCore with Nanotechnology will fulfill the above requirements.

Creating platforms to support the necessary NanoCore elements requires performance, flexibility and extensibility in the underlying hardware/software infrastructure. DSP farms are required for media conversion and transcoding while the latest high performance computing processors take care of all the control and signaling functions. The need to combine these functions within a highly available and "network ready" chassis makes AdvancedTCA the ideal architecture. AdvancedTCA enables the appropriate connectivity as well as the infrastructure to support high density DSP cards.

Now a day's nanotechnologies are used in DSP Fabrication. Much more new perceptions are introduced in DSP designing which increases the overall system speed & capacity.

Quantum Computing:

Quantum computing is the area of study focused on developing computer technology based on the principles of quantum theory, which explains the nature and behavior of energy and matter on the quantum (atomic and subatomic) level.

In modern digital computers, information is transmitted by flowing electricity in the form of electrons, which are negatively charged subatomic particles. Transistors in computers are electrical switches that store data as "bits," in which "off" (no electrical charge) and "on" (charge is present) represent one bit of information: either 0 or 1.

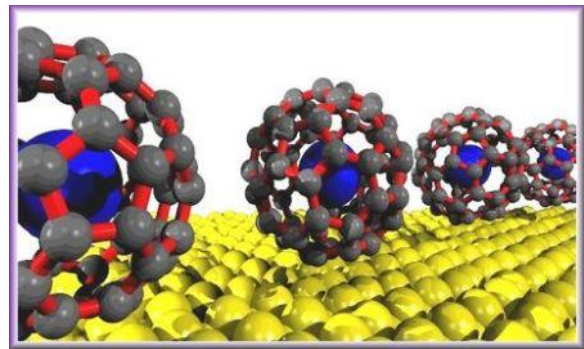

For example, with three bits, there are eight possible combinations of 1 or 0: 1-1-1, 0-1-1, 1-0-1, 1-1-0, 0-0-0, 1-0-0, 0-1-0 and 0-0-1. But three bits in a digital computer can store only one of those eight combinations at a time.

Quantum computers, which have not been built yet, would be based on the strange principles of quantum mechanics, in which the smallest particles of light and matter can be in different places at the same time.

In a quantum computer, one "qubit" - quantum bit - could be both 0 and 1 at the same time. So with three qubits of data, a quantum computer could store all eight combinations of 0 and 1 simultaneously. That means a three-qubit quantum

computer could calculate eight times faster than a three-bit digital computer.

Typical personal computers today calculate 64 bits of data at a time. A quantum computer with 64 qubits would be 2 to the 64th power faster, or about 18 billion billion times faster. (Note: billion billion is correct.)

Quantum computers have the potential to perform certain calculations significantly faster than any silicon-based computer.

Improved Storage capability:

One of the major requirements of Nanocore is that ability to store large amount of data. More and more modern electronic devices need larger memories. Current technology makes these demands very difficult to meet, but nanotechnology offers the solution.

Nanodots:

One such new data-storage device in R&D is the use of nanosized 'dots' of nickel which it is hoped could be used to store terabytes of data, even for home and personal users. Considering the relatively large (physically) storage devices we have now, and the fact we tend to currently refer to size in terms of gigabytes, the amazing potential is plain to see.

Each "nanodot" consists of a discrete ball of several hundred nickel atoms and can have one of two magnetic states. This allows them to

hold a single bit of information - a '1' or a '0' - as is the computing convention. In current hard drives, bits (of information) must be placed far enough apart so as not to interfere with each other.



Nanodots operate as complete units which are not structurally linked, therefore allowing them to be packed closer together. They arrange themselves at such a density that should allow anything up to 5 terabytes (5000GB) of data to be stored in a space the size of a postage stamp. Work still has to be carried out to allow these nanodots to operate and interact with other computing devices, such as silicon chips, but the technology is definitely showing promise.

The Nanodot is appropriate for both NE as well as Nanocore. It will be implemented in both the part.

Improved speed:

To please its customer 5G needs to comprise a fast access to its services, Nanocore requires a far-

fetches speed to process those multiple requirements.

Optoelectronics: Faster transfer of data within and between devices can be achieved using nanotechnology. A major limitation in transfer speeds is the use of electrical wiring and contacts. The use of optical fibres revolutionized the telecommunications industry by increasing the rate of data transfer between components. Optoelectronics can dramatically increase data transfer rates within devices such as pc's by replacing copper wiring. In the future for example, it could be possible to use quantum dot based lasers to transfer information between components within devices at the speed of light, with each piece of information 'coded' by being a unique wavelength of light.

Externally, by increasing the number of nodes in information networks, data can be transferred more rapidly between two points. This will become possible through the development of cheap ambient sensor networks based on nanotechnology.

Nanotechnology is certain to improve Nanocore network and be a strong force in developing new ones. The field is progressing, but considerable work must be done before we see its full impact.

Improved security:

While considering Nanocore as a global server where user can access his real time applications, there should be a special anxiety given to the

security. Security of data which being transmitted should be protected all the way.

Quantum cryptography: Critical component of quantum communication device may enable cryptography. Quantum cryptography is an emerging technology currently used by both military and financial organizations to send information as entangled particles of light. In theory, anyone who tries to tap into this information changes it in a way that reveals their presence. This type of technology can be used in particular cases like when the military needs to send the key to encrypted data across the world, it can't necessarily rely on today's communication lines.

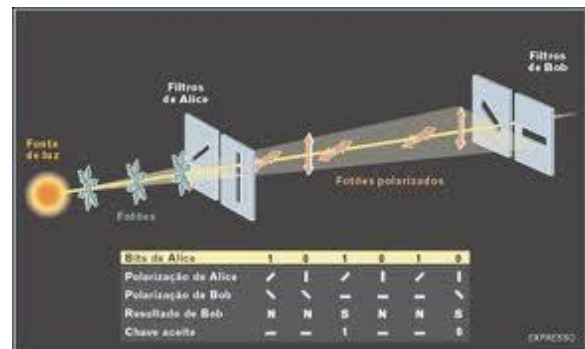

However in 5G networks where user will be accessing all kinds of significant messages from different platforms, can make use of this quantum cryptography to avoid harmful hazards.

Cloud Computing:

Cloud computing is a technology that uses the internet and central remote server to maintain data and applications. In 5G network this central remote server will be our content

provide. Cloud computing allows consumers and business to use applications without installation and access their personal files at any computer with internet access. The same concept is going to be used in Nanocore where the user tries to access his private account form a global content provider through Nanocore in form of cloud.

The development of cloud computing provides operators with tremendous opportunities. Since cloud computing relies on the networks, it shows the significance of networks and promotes network development. It also requires secure and reliable service providers, capabilities that operators have deep expertise in. Operators can enter the cloud computing market and create new value-added services and experiences by integrating industry content and applications in the digital supermarket model.

This could make our user to obtain much more real-time application to utilize his 5G network efficiently. Secure and reliable service can be provided with the help of quantum cryptography.

Cloud computing customer avoids capital expenditure for the Nanocore thereby also reducing the cost of purchasing physical infrastructure by renting the usage from a third party Provider(Content Provider). The Nanocore devours the resources and pay for what it uses.

Segments of Cloud Computing:

Cloud computing has three main segments which are as follows:

1. Applications
2. Platform
3. Infrastructure

Each segment serves different products for businesses and individuals with different purposes.

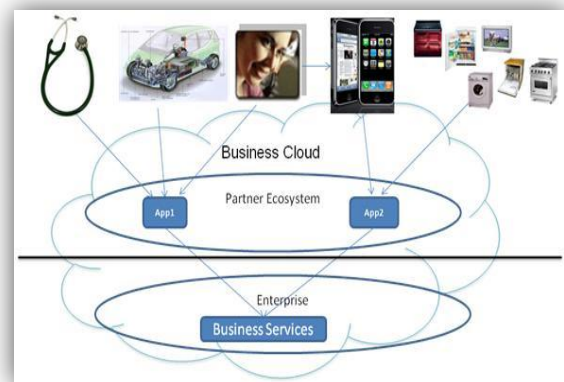

Applications - It is based on, on demand software services. On demand software services come in different varieties. They vary in their pricing scheme and how the software is delivered to the end users. In the past, the end-user would purchase a server that can be accessed by the end user over the internet.

Platform - The platform segment of cloud computing refers to products that are used to deploy internet. Net Suite, Amazon, Google, and Microsoft have also developed platforms that allow users to access applications from centralized servers. Google, Net Suite, Rack space cloud, amazon.com and sales force are some of the active platforms.

Data will flow more freely as mobile communications networks move toward a "flat IP" model, but developers and operators will face new security challenges. This kind of security challenges can be trounced by nanotechnology.

The key aspects of the All IP:

- Support for a variety of different access systems
- Common capabilities provided independent to the type of service provided with convergence to IP technology considered from the perspective of the system as a whole
- High performance mobility management that provides end-user, terminal and session mobility
- Ability to adapt and move sessions from one terminal to another
- Ability to select the appropriate access system based on a range of criteria
- Provision of advanced application services as well as seamless and ubiquitous services
- Ability to efficiently handle and optimally route a variety of different types of IP traffic including user-to-user, user-to-group and ubiquitous service traffic models
- High level of security and support for user privacy e.g. location privacy, identity privacy
- Methods for ensuring QoS within and across AIPNs

- Appropriate identification of terminals, subscriptions and users
- Federation of identities across different service providers

MultiCore Technology:

To support IP based architecture Nanocore should incorporate multi core technology in it. The shift to multi core technology to run advanced IP-based applications and services is well underway. Multi core technology has certainly introduced the hardware required for powerful processing demanded by converged telecommunications and enterprise applications running on IP-based architectures.

NanoCore –As Managed Services:

Sharing of infrastructure is becoming more general among telecom operators now days as they can give fine revenue. Normally there are two types of infra sharing

- Active Infra sharing
- Passive Infra sharing.

Commercial deployment of Nanocore approach's a passive infra sharing where several operators can have a single shared Nanocore for their network enhancement. This could reduce their initial CAPEX requirements. Nanocore can be governed by a solitary global vendor or it can be shared among small vendors as managed services. This could make better sense in terms of Quality aspects.

In rare cases Nanocore can be overseen by the government itself. Everything depends on its enthusiastic. If this happens all our existing operators will become Mobile Virtual Network Operator (MVNO).

Future Enhancement: The future enhancement of Nanocore will be incredible as it combines with artificial intelligent (AI). One can be able to control his intelligent Robot using his mobile phone. Human life will be surrounded by artificial sensors which could be communicating with your mobile phones. Your Mobile can automatically type the message what your brain thinks. We might get a circumstance where we don't require any spectrum for communication. We might be communicating with people on other planets using mobile phone December 1, 2010es. We might have a single NanoCore common for all the nations. This might improve mobility of user as well as a smaller amount of billing to end user. Who knows some times we may communicate with the supernatural things with our mobile phones. Everything depends on how human being is going to utilize these technologies in an innovative manner.

Risk & Challenges: Each technology has its own risks & challenges. One of the major risks is that when things get globalized chance of fraudulent will be uncomplicated. Main challenge for 5G

network is security concern. There should be stability between technologies which is incorporated in NanoCore to form as 5G. Even though 5G core is a miniaturized version. Cost of NanoCore will be more as it incorporates Nano devices in it, which are of high cost. Operator should realize the massive applications of 5G when he thinks for CAPEX. HW/SW specification of NanoCore could be one of the major challenges of 5G. Special care should be taken such that usage of novel technologies should not harm human health.

Conclusion:

While the future is becoming more difficult to predict with each passing year, we should expect an accelerating pace of technological change. We conclude that nanotechnology, Cloud computing, All IP are the next great technology wave and the next phase of Moore's Law. NanoCore innovations enable Myriad disruptive businesses those were not possible before, driven by entrepreneurship. We hope that this Paper helps to promote stronger links between people working in different fields creating future concepts of mobile communication, Internet services, Cloud computing, All IP network, and Nanotechnologies. We conclude that it is a great time to invest in startups. As in evolution and the explosion, many will become extinct. But some will change the world. So we pursue the strategy of a diversified portfolio.

References:

1. IBM Research News.
2. Nanowerk - Nanotechnology research News.
3. Nanotechnology Applications to Telecommunications and Networking, by Daniel Minoli.
4. Nanotechnologies for Future Mobile Devices by TAPANI RYHÄ, NEN Nokia Research Center, Cambridge

Case studies:

Now our major anxiety is that when this 5G core evolve? Research's expects it by 2033; we can perceive a change in wireless technologies with the impact of convergence of different technologies. Still researches are going on all over the world for convergence of technologies.

- Nokia - Adventures in Nanotechnology - Nokia together with the University of Cambridge (UK), has developed this concept called Morph.
- Human heartbeats could one day power cell phones! - Prof. Keon Jae Lee (KAIST, Dept. of Materials Science and Engineering) and Prof. Zhong Lin Wang (Georgia Institute of Technology, Dept. of Materials Science and Engineering)
- IBM nanotechnology might improve cell phones.
- Portugal Telecom makes the first 100G connection in Portugal over its optical fiber network
- Nanotechnology soon could enhance cell phones with carbon-nanotube vacuum tubes, microscopic microphones, liquid lenses, compasses

linked with global positioning system satellites and even electronic noses- NEW YORK, May 31 (UPI).

- For the communications networks underlying the phones, Bell Labs researchers are creating soccer-ball-sized devices that can handle a petabit -- or a million billion bits -- of data.
- Securing aeronautical communications using quantum cryptography- Le Quoc Cuong, Nguyen Toan Linh Tam, Nguyen Thanh Mai, Patrick Bellot
- Two of Russia's mobile networks are planning trials of train ticket payments by mobile phones. In Moscow, MTS will run a trial with the Moscow Metro started from next January, while in St Petersburg a separate trial will take place with rival mobile network, MegaFon.



--The Paper is scripted by Imthiyaz Ali,

imthiyaz.ali@wipro.com

Reach me - imthiyazece@sify.com

Linked In - [Imthiyaz Ali LinkedIn Profile](#)

Face Book - [Face Book Account](#)

Twitter - <http://twitter.com/imthiyaz5g>

Follow us on - www.5gthenanocore.com

Let's Shape the Future



To be continued...